

P.O.#	CUSTOMER	DATE:
-	-	-

8	7	6	5	4	3	2	1
---	---	---	---	---	---	---	---

DWN NO. GENERAL		REV. 1 A	
REVISIONS			
ZONE	REV	ECCO NO.	DESCRIPTION
A			RELEASED TO PRODUCTION
DATE	APPROVED		

NOTES:
 1. MOTOR REQUIRES "AIR OVER" FOR CONTINUOUS OPERATION.
 2. VERTICAL POST HAS NO SEAL.

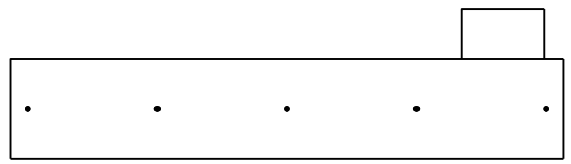

TOP VIEW

APPROVED
 BY: _____

QTY=1

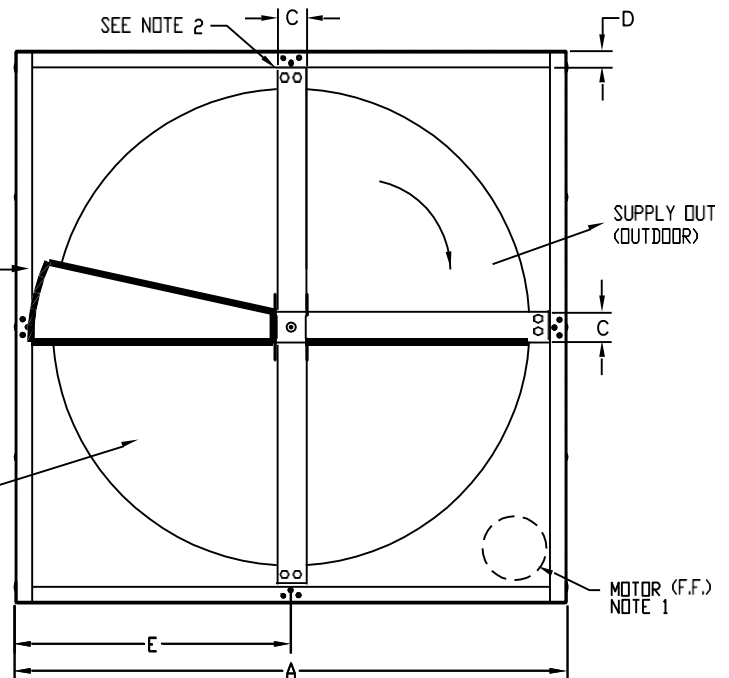

FRONT VIEW

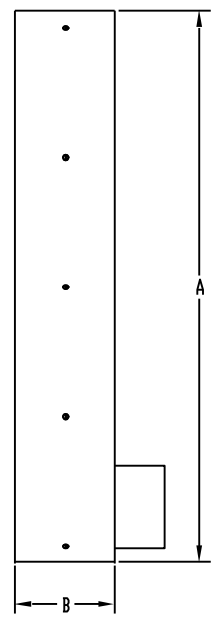

SIDE VIEW

WHEEL SIZE	DIM. A	DIM. B	DIM. C	DIM. D	DIM. E	MOTOR SPECIFICATIONS FOR CUSTOMER USE	MTR
ECW284	34	7	2	1	17	1/3 H.P., 825 R.P.M., 208/230V 1ø	
ECW324	39	7	2	1	19.5	1/2 H.P., 1140 R.P.M., 115-208/230V 1ø 1/2 H.P., 1140 R.P.M., 208-230/460V 3ø	
ECW364	42	7	2.5	1	21	1/2 H.P., 1140 R.P.M., 208-230V 1ø 1/2 H.P., 1140 R.P.M., 208-230/460V 3ø	
ECW384	44	7	2.5	1	22	1/2 H.P., 1140 R.P.M., 115/208-230V 1ø 1/2 H.P., 1140 R.P.M., 208-230/460V 3ø	
ECW424	48	7	2.5	1	24	1/2 H.P., 1140 R.P.M., 115/208-230V 1ø 1/2 H.P., 1140 R.P.M., 208-230/460V 3ø	
ECW484	54	8	2.75	1	27	1/2 H.P., 1140 R.P.M., 115/208-230V 1ø 1/2 H.P., 1140 R.P.M., 208-230/460V 3ø	
ECW544	60	8	2.75	1	30	3/4 H.P., 1075 R.P.M., 208-230V 1ø 3/4 H.P., 1140 R.P.M., 208-230/460V 3ø	
ECW604	66	8	2.75	1	33	3/4 H.P., 1075 R.P.M., 208-230V 1ø 3/4 H.P., 1140 R.P.M., 208-230/460V 3ø	

SPECIAL MOTOR SELECTION

DO NOT SCALE DRAWING		CONTRACT NO.			
UNLESS OTHERWISE SPECIFIED: .X DECIMAL ± .1 .XX DECIMAL ± .03 .XXX DECIMAL ± .010 ANGLES ± °		APPROVALS	DATE		
ALL DIMENSIONS ARE IN INCHES		DRAWN: M. HARRISON CHECKED: M. HARRISON ISSUED: _____ APPROVED: _____		TITLE: SINGLE FACE PANEL CASS GENERAL ARRANGEMENT FOR 100MM WIDE WHEELS	
PART DASH NO.	NEXT ASSY	USED ON	APPLICATION	SIZE	REV
				D 80298	GENERAL A
INTERPRET PER 000-910-100				SCALE: NONE	WT.

8	7	6	5	4	3	2	1
---	---	---	---	---	---	---	---