

# NOVELAIRE

Creating The Great Indoors®

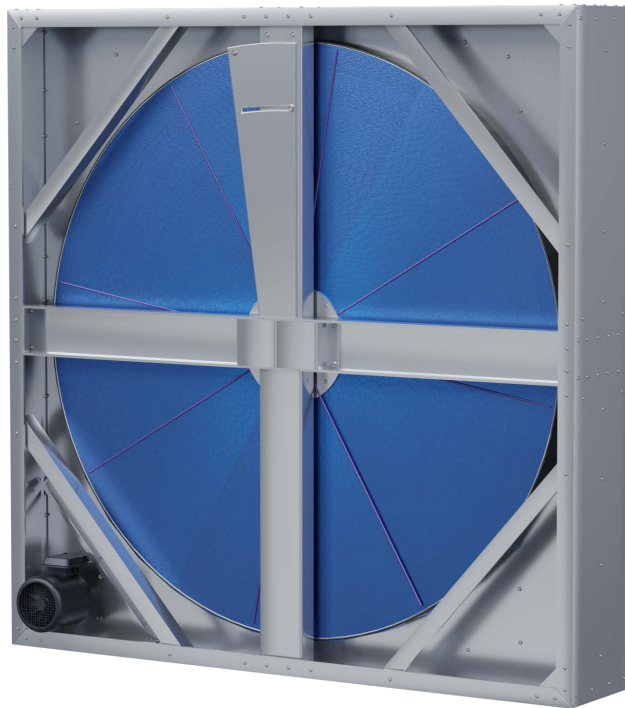

Energy Conservation Wheel  
Operating and Maintenance Manual

## CONTENTS:

### SECTION I: Introduction and Definitions.....3

Introduction.....3

Definitions .....3

### SECTION 2: Receiving and Inspecting.....4

Receiving.....4

Lifting and Handling.....4

Storage.....4

*Figure 1- Cassette Components* .....4

### Section 3: Installation.....5

Identification Markers.....5

Installing.....5

*Figure 2- Cabinet Installation Guide* .....5

### Section 4: Controls and Wiring.....6

Drive Motor.....6

Variable Speed Control.....6

Frost Prevention Measures.....6

### Section 5: Startup and Operation.....7

Prestartup Checks .....7

Seal Checks.....7

Variable Frequency Drive (VFD).....7

Adjustable Purge.....7

### Section 6: Maintenance.....8

Bearings.....8

Drive Motor .....8

Drive Belts.....8

Seals.....8

Wheel Cleaning.....8

Basic Cleaning .....8

Wheel Washing within Cabinet: .....8

Wheel Washing Removed from Cabinet: .....8

Variable Frequency Drive.....9

### Section 7 – Belt Installation.....10

Sheet Metal Cassette Belt Installation .....10

Welded Box Tube Belt Installation.....13

### Section 8: Troubleshooting.....15

Appendix 1 – Powertwist Belt.....16

Appendix 2 – External Pillow Block Bearing.....17

Appendix 3 – External Flange Bearing .....18

Appendix 4 – Internal Insert Bearing.....18

Appendix 4 – ECW General Arrangements.....19

## SECTION I: INTRODUCTION AND DEFINITIONS

### INTRODUCTION

Your NovelAire Technologies energy conservation wheel (ECW) cassette comes complete and ready to run. The ECW cassette is built to provide many years of trouble-free service. With proper installation and performance of the minimal maintenance requirements, your ECW should operate problem free.

Please review these instructions carefully before installing the unit. Most damage occurs due to improper installation. NovelAire is not responsible for a unit that has been improperly installed. The rotor media can be torn or crushed by mechanical means if the unit is improperly treated.

This document covers operating and maintenance instructions for both the total heat wheels (ECW) and sensible only wheels (SEW).

For questions, please contact NovelAire Technologies at:

Ph: (800) 762-1320 or (225)  
924-0427 Fx: (225) 930-0340  
Email: [info@novelaire.com](mailto:info@novelaire.com)

### DEFINITIONS

**Bearing, external** - Flanged or pillow block bearing used with rotating shaft models in larger, welded units.

**Bearing, internal** - Sealed ball bearing used with fixed shaft models in smaller, sheet metal units.

**Brush seal** - The seal used for both the perimeter seal and the face seal in the NovelAire ECW cassettes. They are constructed of nylon brushes and seal against the wheel band in the case of the perimeter seal and are siliconized and positioned against the wheel surface in the case of the face seal. These seals are noncontact in that there is a slight gap between seal and sealing face to allow the wheel to turn at high RPMs without over-torquing motor or causing seal damage. These seals have an integral clip and are clipped to the cassette face panel cutout (perimeter) or to the post (face).

**Cassette** - The steel structure that houses the rotor. ECW cassettes are of punched sheet metal panelized construction. Large cassettes are of welded box tubing construction.

**Energy Recovery Unit (ERV)** - The unit that the ECW fits into. This will typically include two blowers and the ECW cassette all enclosed in a sheet metal housing.

**Enthalpy wheel** - A generic name for an energy conservation wheel. The term enthalpy refers to an air stream's total energy (temperature and humidity level).

**Exhaust air** - The air stream leaving an ECW that is exhausted to the outside. Exhaust air is building return air that has been run through the wheel.

**Heat wheel** - Synonymous with enthalpy wheel, energy conservation wheel, or total energy recovery wheel. Some heat wheels are sensible only wheels and should not be confused with total energy recovery wheels.

**Hub** - The center support of an ECW.

**Latent energy** - Latent energy in the context of wheel discussions is the work done by the wheel to transfer moisture from one air stream to another. Latent work is accompanied by humidity changes in the air streams.

**Media** - The chemical composite part of the wheel which performs the latent and sensible exchange.

**Outdoor air** - The air stream entering an ECW that is brought in from outside. Outdoor air becomes supply air after going through the wheel.

**Purge** - A small segment of supply air defined by the gap between the inner seal on the outdoor air edge of the center post and the supply air edge of the center post. The purge angle is adjustable. The purge captures the small amount of supply air captive in the wheel when the wheel moves from return to supply and routes it to the return air to minimize cross contamination.

**Return air** - The air stream entering an ECW that is returned from the building. Return air becomes exhaust air after going through the wheel.

**Rotor** - The part of an ECW that does the energy exchange and consists of the wheel media, hub, spokes, and band.

**Sensible heat** - Sensible energy in the context of wheel discussions is the work done by the wheel to transfer heat from one air stream to another. Sensible work is accompanied by temperature changes in the air streams.

**Sensible wheel** - A wheel that does only sensible work, i.e., where only heat is transferred from one air stream to another and the resultant moisture level remains essentially unchanged.

**Spoke** - Flat metal member used to support the wheel radially.

**Supply air** - The air stream leaving an ECW that is supplied to the building space. Supply air is outdoor air that has been run through the wheel.

## SECTION 2: RECEIVING AND INSPECTING

### RECEIVING

Upon arrival of your ECW, please inspect cartons, pallets, and packaging for any damage that may have occurred during shipping. Neither NovelAire nor its customer is responsible for shipping damage, and it is important to identify any such damage before the unit is offloaded. Report any shipping damage immediately to shipper and NovelAire Technologies so that the proper remedies may be taken.

If the unit has come shipped on a pallet, please use proper forklift procedures to offload the pallet. The media can be easily damaged by the forks on the forklift.

### LIFTING AND HANDLING

The ECW comes complete with lifting lugs. Lugs are located on top of the unit housing. Large ECWs have 4 lift points and small ECWs have 2. Use only the lifting lugs to off load an ECW that is not palletized. If the unit is palletized, it may be lifted either by the lifting lugs or with the forks placed underneath the pallet. In no case should the unit be lifted by any other means.

Small ECW units do not typically come with lifting lugs and can be lifted by hand.

### STORAGE

The unit should be stored out of the weather. Make sure the unit is covered to prevent dust and dirt collection on wheel face during long periods of storage.

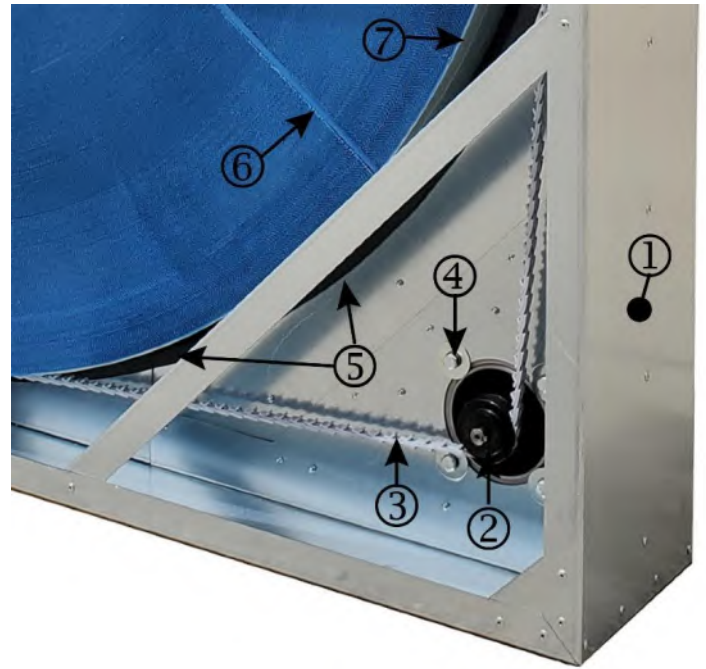

FIGURE 1- CASSETTE COMPONENTS

1. Cassette Housing
2. Drive Sheave
3. Drive Belt
4. Drive Motor Mount Bolts
5. Perimeter Seal
6. Spoke
7. Outer Band

## SECTION 3: INSTALLATION

### IDENTIFICATION MARKERS

Look for any identification markers that have come with your ECW. Rotational direction and/or air stream orientation will be marked on your unit. The air flow orientation should be identical to that of the general arrangement drawing which was provided to you during initial placement of the order. Check to make sure that air flow orientation is as requested. Consult the general arrangement drawing provided earlier. It is important that the unit be installed with the right rotational directions. It is also important that air flows be oriented as designed to allow the purge to function as designed.

Consult NovelAire Technologies if you have problems with any of these instructions or if the unit is improperly marked.

### INSTALLING

Make sure that the installation plan is consistent with identification markers.

Locate the purge side of the unit. The purge should always be in the supply air stream. The ECW accomplishes "purging" by removing a small wedge of supply air and routing it to return air. Thus, when the wheel is in rotation, the small amount of stale return air that is trapped in the wheel section rotating from building to outdoor air side is isolated and routed to the exhaust air stream.

The installation requires ducting to 4 air streams.

***It is good practice to include means for accessing the ECW cassette on all sides. This can be done either using 4 access doors, or 2 access doors with provisions for a removable section of front and back duct. NovelAire recommends including a removable plenum section (see Figure 2) in the front and back of the cassette for expedient repair and/or wheel removal. Alternatively, the cassettes can be installed on a slide-out track for easy access. Access must be provided to the shaft and bearings for servicing.***

Before installation, inspect the cassette for loose screws or bolts. Tighten any loose connections.

Small units (under 60 inches) can be installed in either a horizontal or vertical orientation. Larger units must be pre-engineered to run in the horizontal position as they require thrust bearings and additional supports. If the unit was not pre-ordered to run horizontally, do not install the unit horizontally. Vertical units should be supported from the bottom in the installed position. Horizontally mounted units should be supported at all four corners and in the center.

Before installing, turn the wheel by hand in the direction of rotation to ensure that the wheel alignment was not altered in shipping. If severe binding occurs, it could be due to excessive seal contact. In this case, adjust the seals according to the instructions given in the seal adjustment procedure in section 5.

The ECW seals were preadjusted before leaving the factory. If upon inspection excessive clearance between seals and sealing surfaces is found, adjust the seals according to the procedure given in section 5.

Inspect the drive belt and make sure that it is securely fastened around the drive sheaves and wheel. If possible, test run the wheel before installation.

Install the unit. Once the unit is in place, secure the ductwork to the cassette with sheet metal screws, bolts, welding, or alternate method of attachment. Gasketing may be used at the joints, but it must be installed securely so that it cannot detach and cause rotor damage. The duct work should be securely fastened to the cassette at all locations.

The wheel should be protected using an ASHRAE 30% filter installed in both the outdoor air and return air streams.

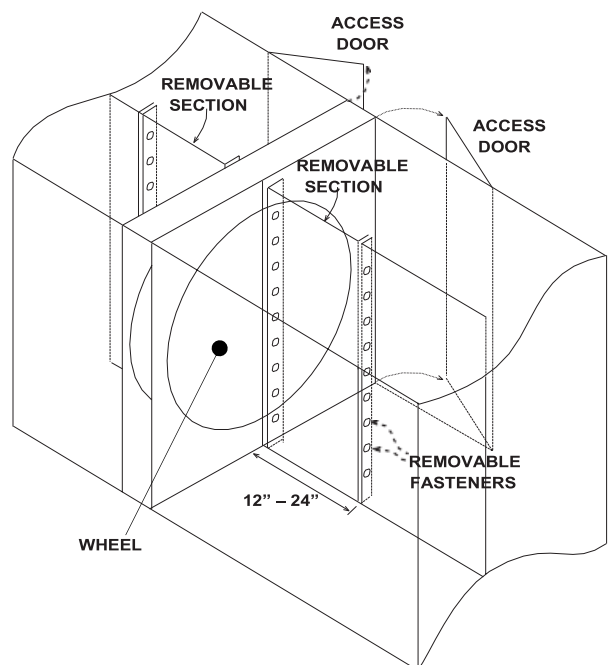

FIGURE 2- CABINET INSTALLATION GUIDE

Suggested access doors and removable panels to facilitate wheel removal.

## SECTION 4: CONTROLS AND WIRING

### DRIVE MOTOR

The ECW comes standard with a constant speed drive motor at a voltage requested by the customer. The typical motor voltage options are: 115/208-230v 1 phase, 208-230/460v 3 phase, or 575v 3 phase. ECW motors are standard motors and should be wired like any standard motor. For multi-voltage motors, ensure to read and follow the wiring schematic on the motor or manual for the applicable voltage required in the unit.

Single phase motors come prewired for correct rotation direction, but rotation direction should be verified. Three phase motors must always be checked for correct rotation direction as the local power determines which direction the wheel will rotate when power is connected.

Follow the directions on the motor schematic accompanying the motor. Once the motor is wired, test run the ECW and check for proper rotation.

### VARIABLE SPEED CONTROL

If the variable speed option has been supplied, the variable frequency drive's (VFD) power rating, power supply, and motor selection have all been matched up by the manufacturer. The unit can accept either a 4-20ma or 0-20ma control signal or a 0-5VDC or 0-10VDC. The unit has also been programmed for the range of wheel speed operation recommended by the manufacturer. Typical wheel speed is 35 RPM, but the programming can allow for wheel speeds above or below 35 RPM. Check all factory settings to make sure they are consistent with the application. Consult NovelAire for any help in achieving the right setup for the application.

The VFD may have been shipped loose for flexibility in mounting. Locate the VFD where it can be read and reached easily. Mount the VFD where it is protected from the weather.

The control signal to the VFD is customer supplied, but typically it will be either a temperature or a humidity reading. Typical wheel speed will be controlled either by exhaust humidity or exhaust temperature measurement. Some applications for sensible wheel exchangers in desiccant cooling systems may call for wheel speed controlled by supply temperature.

### FROST PREVENTION MEASURES

During extremely cold wintertime conditions, frost formation becomes a possibility. The stream that is under risk from frost formation is the exhaust air stream. Frost formation will basically act to plug or reduce air flow and will not hurt the wheel itself.

Wheel speed control works to limit frost formation by reducing wheel performance to a level where the exhaust air temperature is kept above the dew point. Proper dew point control of exhaust air can be determined using a psychrometric chart by:

1. Locating the wintertime design return air condition and outdoor air condition and connect the two points on a psychrometric chart.
2. Determine the dry bulb temperature at which this line intercepts the saturation curve.
3. Add 2 degrees and set dew point control at this point and vary wheel speed downward to control at or above this point.
4. Audit performance of the wheel during actual operation. If frost formation is never evident, it may be because design conditions are never reached in which case it may be possible to gradually work dew point control down.

Some of the frost control methods ([www.ahrinet.org](http://www.ahrinet.org)) that can be used for all types of exchangers are:

**Exhaust only:** When frost is indicated on the component, the intake blower is de-energized for a period of time to allow exhaust air to warm component, melt frost, and drain or evaporate condensate. Alternatively, exhaust-only operation is determined based on outside air temperature to avoid frosting.

**Preheat:** For outdoor air preheat, heat is provided in the outdoor air intake to heat the air to a temperature above the exchanger frost threshold before it enters the component. Alternatively, for return air preheat, heat is provided in the return air before it enters the exchanger to prevent frost from forming.

**Re-circulation:** When return air or exhaust air re-circulation is used, return air or exhaust air is substituted, in whole or in part, for outside air passing through the exchanger for defrost purposes.

**Bypass:** A portion of the outdoor air is bypassed around the exchanger until the frost threshold is avoided.

## SECTION 5: STARTUP AND OPERATION

### PRESTARTUP CHECKS

Before starting up the unit, check the following:

1. Does the rotor rotate freely by hand? If not, recheck the seal to determine whether it is binding and if so, adjust seals following the instructions below.
2. Is the motor rotation correct? This can be checked by detaching the belts from the drive sheave and bumping the motor. The sheave should be rotating in the direction such that the belt will result in rotation per the exterior markings. If not, rewire the motor.
3. Does the air flow orientation match up to design? See the identification markings on the cassette and/or refer to the general arrangement drawing to check the four duct connections to the unit.
4. Are the belts on correctly and sufficiently tight? Belt length is set by the manufacturer. Consult NovelAire if the belt appears too loose.
5. Is the VFD programmed to control the unit and to prevent frost formation? If not, follow the instructions in the manual accompanying the VFD and/or consult NovelAire.

### SEAL CHECKS

The ECW is provided with a nylon brush seal which provides not only an effective seal in both the peripheral and side-to-side sealing directions but also one which is easily adjusted to compensate for seal run-in, shipping misalignment, etc. The brush seal is attached to a metal reinforced U-shaped neoprene grip. The metal/neoprene grip allows for an expandable grip range which can be moved closer or further from the sealing face as needed. The perimeter brush seals against the wheel outer band and the inner, siliconized brush, seals against the wheel face. With the wheel stopped, move seals as close to the sealing surface as possible but without exceeding grip range of brush seal and without pressing the brushes down against the seal face. Bump the motor. If the motor will not turn, the seal is too close and should be nudged back where needed. The seal will seek its equilibrium position based on the closest part of the sealing face. Seal leakage is meant to be under 5% at 1 inch of differential between supply and exhaust.

Some seal run-in is to be expected, so do not be alarmed by small amounts of wear on the nylon brushes.

### VARIABLE FREQUENCY DRIVE (VFD)

Check the power supply for proper rating. Make sure that the proper jumper orientation is used for the specific control input.

Make sure that the unit is programmed for proper input voltage and output voltage.

Always refer to the specific VFD documentation that is provided with the ECW cassette or contact NovelAire for support.

### ADJUSTABLE PURGE

The adjustable purge on the ECW is in the supply air stream and, depending on configuration ordered, will be either vertical or horizontal, left, or right side. It is set from factory at 0° and is adjustable from 0° to 12° to reduce cross-contaminated air.



Purge sections minimize cross leakage by shunting a portion of the supply air back into the exhaust air stream and can limit cross leakage to less than 1%. Studies have shown that changing the purge angle from 0° to 12° has only a small impact on the effectiveness (energy transfer) of the energy conservation wheel (2%-3%), while the reduction in gaseous carryover is substantial. The degree to which the purge angle should be adjusted is dependent on:

1. Differential pressure between supply and exhaust air streams
2. Air velocity
3. Wheel design (diameter, thickness, & flute geometry)
4. Wheel rotation speed

To be able to set the purge correctly, the optimal angle can be determined using our web-based ECW wheel software available at: [www.novelaire.com](http://www.novelaire.com)

The pressure differential between the supply out ( $S_o$ ) and exhaust in ( $E_i$ ) side of the wheel has a significant impact on the cross leakage and gaseous carryover. If the pressure differential ( $S_o - E_i$ ) is negative, the driving force for leakage is towards the supply side resulting in carryover. This condition must be avoided through proper design/configuration of the unit. Contact NovelAire for support or review the ASHRAE ERV design guides.

<https://www.ashrae.org/technical-resources/energy-recovery>

## SECTION 6: MAINTENANCE

### BEARINGS

Small ECWs (ECW726 and smaller) are provided with no maintenance inboard bearings. These bearings should require no maintenance during the life of the equipment. Larger ECWs come equipped with an external flanged or pillow block bearing which should be greased annually. Use a lithium-based lubricant.

### DRIVE MOTOR

The drive motors should require no maintenance. Replacement motors may be purchased from normal motor distributors such as Grainger, or directly from NovelAire if preferred.

### DRIVE BELTS

NovelAire ECW belts are multilink belts with individual links constructed of a high-performance polyurethane elastomer reinforced with multiple plies of polyester fabric. This belt provides a strong, yet flexible belting. The multilink feature provides quick, easy servicing or replacement. See Section 7 for belt repair, replacement, & re-tensioning instructions.

### SEALS

The seals are designed to be durable and require no maintenance other than adjustment, but if seals become worn or damaged, they may easily be replaced. The seals are made to clip on the cassette or post metal easily.

Call NovelAire for servicing information.

### WHEEL CLEANING

The wheel is designed to last the life of the equipment. It should be protected by an ASHRAE 30% filter to keep dust and dirt from the heat transfer surface. The wheel is somewhat self-cleaning through its normal action of rotating in and out of countercurrent air flow streams.

**BASIC CLEANING** - Requires access to both sides of the wheel and can be cleaned within the unit using the following method:

1. Using a shop vac, vacuum any debris from both faces of the wheel. Slowly work around the entire face of the wheel to complete the procedure. Do not damage wheel face by excessive pressure of the vacuum nozzle on the wheel face.
2. Using 20 psig clean, dry air, and a small air nozzle, blow air through one face of the wheel. At a similar location on the opposite side of the wheel, gently apply a shop vac to catch any debris exiting the wheel.

If this method does not remove visual buildup or return pressure drop to within normal parameters, a wheel washing procedure may be done. NovelAire wheels can be washed thoroughly with water without affecting the performance of the wheel. The wheel will simply dry out following a washing procedure and resume normal energy transfer performance.

*Note:* If the wheel can be easily removed from the cassette or unit, it is recommended to do so to facilitate the washing process. However, in most cases, it is impractical to remove larger wheels, and therefore, the washing procedure must take place within the air handling unit.

**WHEEL WASHING WITHIN CABINET:** Ensure provisions are made to collect the runoff water from the bottom of the unit or collect the water by using a wet vac on the opposite side of the wheel following the procedure below:

1. Lock out / Tag out the unit and disable the drive motor.
2. Shield all electrical components and bearings with plastic sheeting.
3. Ensure that an adequate drainage system exists to collect runoff water from the bottom of the unit. Alternatively, use a wet vac with a wide nozzle on the opposite face of the wheel to collect the water during the washing procedure.
4. Using standard pressure water (do not use a high-pressure washer) and working from the one side of the wheel, wash the wheel with a standard garden nozzle to flush any debris trapped within the flutes of the wheel. A mild detergent (ie. Simple Green) can also be used to enhance cleaning without effecting the performance of the wheel. No need to drench the wheel with water and must avoid getting the bearings, belts, and motor wet.
5. After washing, blow out excess water with air (20 psig). Vacuum up very lightly with a wet vac. Do not energize the drive motor or begin rotating the wheel yet.
6. Start the fans on both sides blowing through the wheel with the wheel stationary for a few hours to dry the wheel off.
7. Once the wheel is dry, start the wheel motor and resume normal operation.

**WHEEL WASHING REMOVED FROM CABINET:** If feasible, the wheel may be removed from the cassette and washed with water following the procedure below:

1. Lock out / Tag out the unit.
2. Remove air handler plenum sections so that the front or back of the cassette may be easily accessed and cleared.
3. Support the wheel from the bottom.
4. If the unit is equipped with an external flanged bearing, loosen the allen screws in the bearing housing that keeps the shaft affixed in the horizontal plane on both bearing, front

and back. Remove the shaft clips at the face of the hub from both sides of the shaft. Unbolt one post completely and remove post with bearing completely out. Remove the shaft. Roll the wheel carefully out.

5. If the unit is equipped with an internal bearing, unbolt the shaft screw on both sides of the shaft. Unbolt one post completely and remove post. Remove the shaft clips at the face of the hub from both sides of the shaft. Remove the shaft. Roll the wheel out carefully.
6. With the wheel out, wash the media carefully with standard pressure water (do not use a pressure washer) and a mild detergent (ie. Simple Green). Once clean, allow the media to dry out for several hours or days if necessary.
7. Once the wheel is fully dried out, reinstall using the reverse procedure. Run the unit.

## VARIABLE FREQUENCY DRIVE

No maintenance should be required on the VFD. Should problems with the VFD develop, consult the VFD service manual. that accompanied your order or call NovelAire for service information.

## SECTION 7 – BELT INSTALLATION

### SHEET METAL CASSETTE BELT INSTALLATION

The PowerTwist belt is a highly durable and adjustable belt for rotating the wheel. Under typical operating conditions, the belt will last several times longer than competitors V-belts. If there is a requirement to replace or adjust the belt, follow the directions below:

1. Determine direction of wheel rotation. Direction is indicated by arrow label on face panel of cassette. Locate directional arrow on belt.

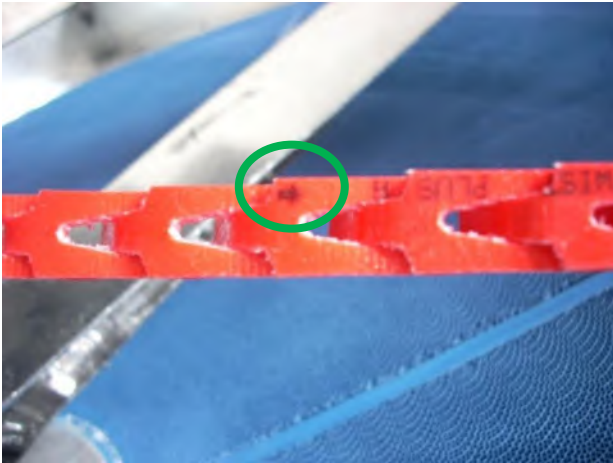

Figure 1

2. Confirm that the arrow on the belt is same direction as the arrow on the cassette. Take one end of belt and begin feeding it around the perimeter of the wheel. Depending on the wheel size, it might be beneficial to use duct tape to hold the belt to the perimeter band and rotate the wheel by hand to feed it fully around the wheel.



Figure 2



Figure 3

3. Feed the other end of the belt to meet up with the leading end while ensuring the belt is not twisted.



Figure 4

- For sizing for the belt length, with both ends meeting up while going around the wheel, they should meet at the drive motor inner mounting bolt. This sizing method is a general guide, and the final belt sizing may require adding or removing links depending on the tension.



Figure 5

- After determining the size, any extra links must be removed to size the final belt. With one hand, hold the belt in a "U". With the other hand twist the indicated tab 90°.



Figure 6

- Pull the end over the rotated tab to disconnect it.



Figure 7

- Rotate the end tab 90°. Pull the end through the links to separate.



Figure 8

- To connect the belt, insert the tab through two links and twist 90° to hold in place.



Figure 9

9. Verify that the belt is near the motor mount inner bolt.



Figure 10

10. Complete the belt linking by twisting the second tab 90° and pushing the belt end over the tab.



Figure 11

11. To complete the mounting of belt, place the belt on the pulley first. At the point where the belt is just off the wheel outer band, pull the belt downward to rotate the wheel and feed the belt fully around the wheel.

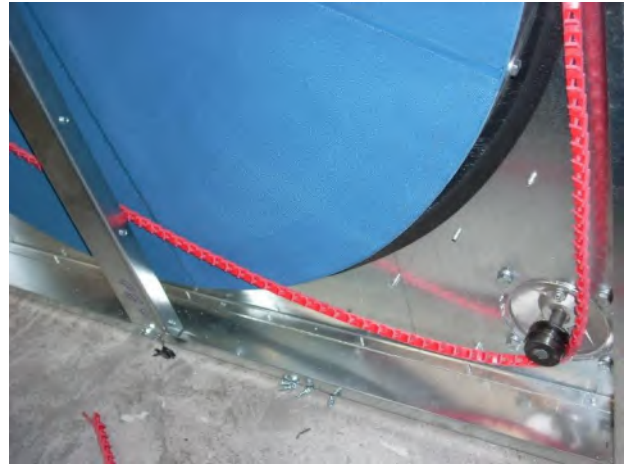

Figure 12



Figure 13



Figure 14

12. As the final step, rotate the belt so that the tabs are to the inside and verify that the linked belt was not twisted during the installation. The installed belt should have the arrows running in the same direction as the wheel with the tabs to the inside of the belt.



Figure 15

13. The belt should be inspected after an hour of running at full load to determine if it requires re-tensioning and that the tabs remain positioned correctly.

#### WELDED BOX TUBE BELT INSTALLATION

For the larger welded box tube cassettes, follow steps 1 through 10 of the sheet metal cassette belt installation instructions. The additional steps below will facilitate the final mounting of the belt on the large wheels.

1. With the belt linked together, it should be placed fully around the wheel. By using a prybar and your available hand, stretch the belt and slide it onto the motor pulley.



Figure 16



Figure 17



Figure 18

2. With the belt now around the wheel and pulley the belt must have the tabs positioned to be on the inside of the belt loop. To facilitate this on the large box tube cassettes, use a 1/2" x 2" bolt & nut, or similar, as shown below.



Figure 19

3. Ensure that the belt is positioned correctly on the motor pulley with the tabs to the inside. Next, place the bolt on the belt as shown.



Figure 20



Figure 21



Figure 22

4. Rotate the wheel by pulling on the leading end of the belt. Perform a full rotation of the belt around the wheel to ensure the tabs are positioned correctly around the wheel and pulley. Remove the bolt after rotating the wheel and before it contacts the pulley.



Figure 23



Figure 24

5. The belt should be inspected after an hour of running at full load to determine if it requires re-tensioning and that the tabs remained positioned correctly.

For additional details on the PowerTwist belt installation, refer to Appendix 1, or review the belt manufacturer's standard installation videos available at: [www.fennerdrives.com/videos](http://www.fennerdrives.com/videos)

Use the following chart to diagnose and correct problems:

<i>Symptom Cause</i>	
Inadequate Wheel Performance	Check wheel rotation speed
	Check for wheel integrity and adjust seals or replace worn seals
	Check entering air conditions and compare to design
	Check ducting for leakage and fix any leaks
	Check media for dirt and clean per cleaning instructions
Improper Wheel Rotation	Check drive belts for engagement with sheave
	Check drive motor
	Check drive motor wiring for proper voltage
	Check VFD programming
	Check VFD input sensor (temp/RH) for malfunctioning
High Pressure Drop	Check air flow compare to design
	Check filters and clean/replace as necessary
	Check media for plugging and clean per cleaning instructions
Noise	Check seals and adjust as necessary
	Check the bearings for source of noise
	Check the belts for slippage

## English HOW TO MEASURE, ASSEMBLE & INSTALL

### How to Measure

To determine the "hand-tight length," route the belt along its intended path (Note: tabs ride in the groove of the sheave).

Overlap the last two tabs of end (A) with two corresponding holes when pulled snug. Mark the hole corresponding to the second tab. Eliminate the extra links by starting the disassembly process (see Disassembly, 1, below) with the tab currently going through the marked hole (as shown in figure to the right). Count the number of links that remain and remove

one link for every 24 of 3L, Z/10, A/4L, and B/5L sections, and one link for every 20 of C and D sections. This gives the correct installed belt length and will ensure proper belt tension while running. For multiple belt drives, ensure each belt has the same number of links.

For 3L, Z/10, A/4L, and B/5L sections: Hand-tight length of belt (# of links) $\frac{\quad}{24}$ = # of links to remove	For C and D sections: Hand-tight length of belt (# of links) $\frac{\quad}{20}$ = # of links to remove
For all sections, round number of links to be removed to the nearest whole number.	

Note: Every tenth link is designated with an arrow (→) (3L, Z/10, A/4L and B/5L only).

### Disassembly

1. Hold belt as shown in figure. Bend back as far as possible; hold with one hand. Twist one tab 90° parallel with slot.
2. Pull end of link over tab.
3. Rotate belt end with tab 90° parallel with slot.
4. Pull belt end through two links.

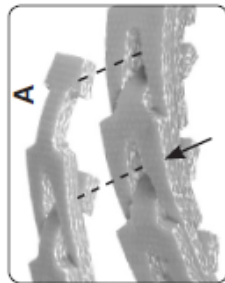
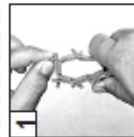

### Assembly

1. Hold belt as shown in figure.
2. Place end tab through two links at once and twist tab into place.
3. Bend back and insert second tab through end link by twisting tab 90° with thumb.
4. Ensure tab returns to position across belt. Reverse belt so tabs run inside.

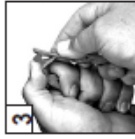

### Installation

1. Turn belt with tabs to the inside before installing.
2. Determine direction of drive rotation.
3. Belt must travel following the belt direction arrow (→) with tabs trailing.
4. Fit belt in nearest groove of smaller pulley
5. Roll belt onto larger pulley, turning the drive slowly. Belt may seem very tight; this is ok; DO NOT JOG MOTOR.
6. Check to see all tabs are still in their correct position and are not twisted out of alignment.
7. For multiple belt drives, work belt from groove to groove. On particularly wide drives, it may be easier to install half the belts from the inboard side and half from the outboard.

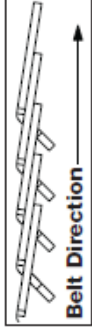

Note: With drive ratios around 1:1, it may be necessary to add back one link to allow belts to be rolled on. This does not apply if using the Alternative Installation Method.

### Alternative Installation Method

1. Set motor to mid-position of adjustment range and mark base clearly.
2. Determine required belt length as in "How to Measure" Section.
3. Push motor forward to minimum center distance.
4. Install belts as in "Installation" Section above.
5. Pull motor back to previously marked mid-position.

### Retensioning

Like all high performance V-belts, PowerTwist Standard V-Belts require the maintenance of correct drive tension to operate efficiently. Experience indicates that drive tension should be checked between 1/2 hour and 24 hours running at full load. A retension may be necessary depending on the application. Any initial belt stretch is then taken up. Subsequently, belt tension should be checked periodically and adjusted when necessary.

View the *PowerTwist Standard installation video at:*  
[www.fennerdrives.com/videos](http://www.fennerdrives.com/videos)



Bearing Reference Guide

E-Family Roller Bearings

Specialty Tapered Products

S-2000

UNISPHERE II

IMPERIAL

UNIFIED SAF

# DIMENSIONS

## IMPERIAL - IP Pillow Block 1-1/8 THRU 2-1/4 INCH - 2-BOLT

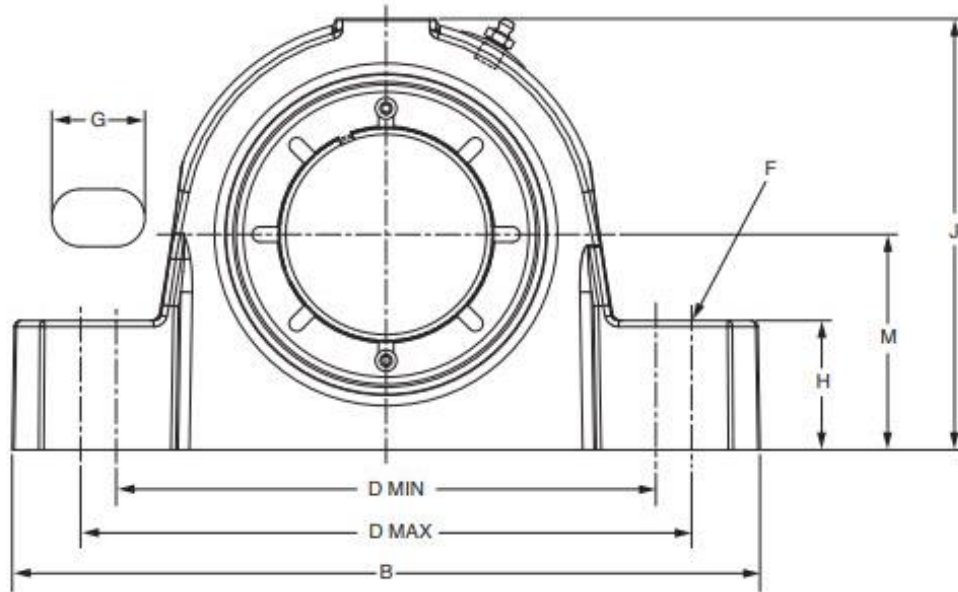

**NOTE:** All sizes use a 1/8-27 NPT hydraulic grease fitting

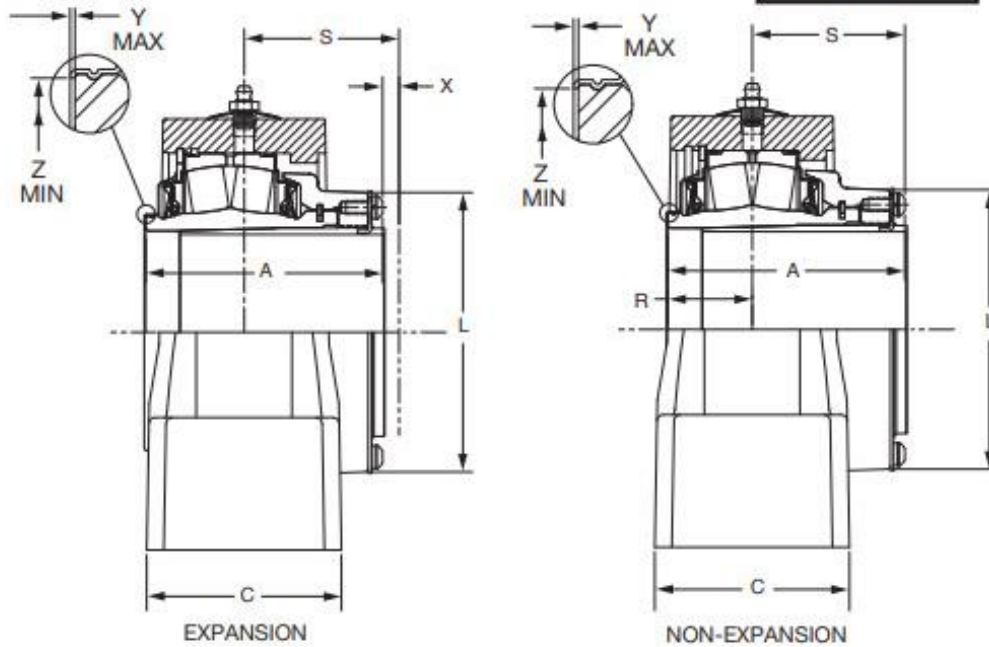

**NOTE:** See page B14-32 for 2-3/8 - 4 inch

FEATURES/BENEFITS PAGE B14-2	SPECIFICATIONS PAGE B14-5	HOW TO ORDER/NOMENCLATURE PAGE B14-8	SELECTION PAGE B14-14
---------------------------------	------------------------------	---	--------------------------

## Flange Units – Standard 2 Bolt FHSFT200-G Series Set Screw Locking

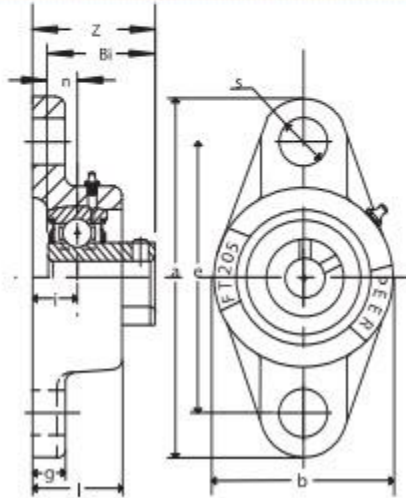

- Standard duty, high-grade cast iron
- Solid base housing design for added strength
- Narrow inner ring bearing
- Relubricatable unit (shown)
- Non-relubricatable unit available (omit "G" from unit part number)
- Standard seal: RST tight riding, full cover, metal shroud seals

Optional seals: See page 85

## Insert Bearings for Units FHS200-G / FHS200 Series Set Screw Locking

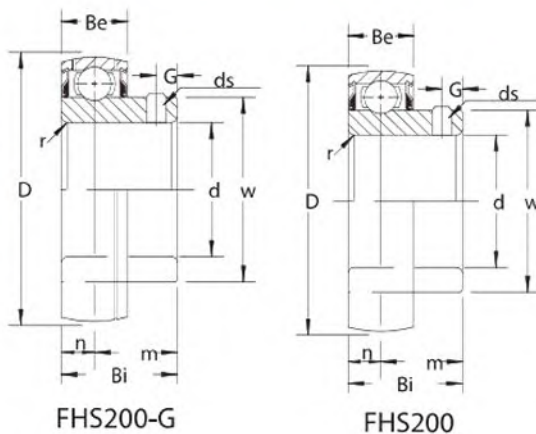
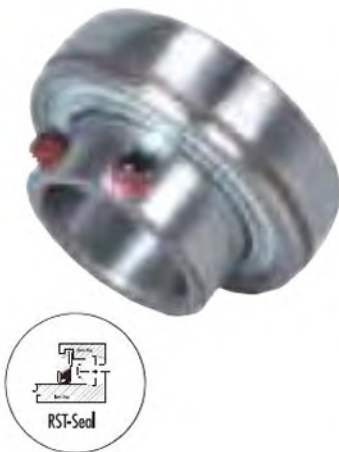

- Standard load capacity
- Narrow inner ring with spherical outer ring
- Relubrication groove with oil hole on set screw side(Shown)
- Oil hole opposite groove makes it interchangeable with all manufacturers (shown)
- Non-relubricatable bearing available (omit "G" from bearing part number)
- Nylon patched class 3A set screws are standard
- Standard seal: RST tight riding, full cover, metal shroud seals

Optional seals: See page 85



# NOVELAIRE

10132 Mammoth Avenue Baton  
Rouge, LA 70814-4420  
Phone: (800) 762-1320  
(225) 924-0427

Fax: (225) 930-0340  
Website: [www.novelaire.com](http://www.novelaire.com)  
Email: [info@novelaire.com](mailto:info@novelaire.com)

The information contained in this manual is believed to be accurate by NovelAire Technologies, LLC, but is subject to revision and not warranted. Please contact your NovelAire sales rep for all current information.