

PrecisionDRY
DH 1000

NOVELAIRE
Creating the Great Indoors™

Commercial Desiccant Dehumidifier
Advanced Humidity Control

PrecisionDRY DH 1000 is a high-performance desiccant dehumidifier engineered for applications where conventional refrigeration-based systems fall short. By leveraging NovelAire's patented desiccant wheel technology, it delivers ultra-low dew points with precision and reliability across a broad range of demanding environments. Typical applications include:

- Archive storage rooms and vaults
- Manufacturing humidity control
- Refrigerated storage
- Mold and mildew prevention
- Corrosion protection
- Water treatment facilities

FEATURES & BENEFITS:

- NovelAire patented high-performance desiccant wheel
- Double-wall, 1" insulated epoxy-coated galvanized steel cabinet
- Direct drive fans with VFDs for precise airflow control
- SCR modulating electric heater for optimized energy use
- Manual/Auto/Off operation with 24VAC run signal compatibility
- Designed for easy maintenance access
- ETL certified



The **PrecisionDRY DH 1000** unit

PERFORMANCE

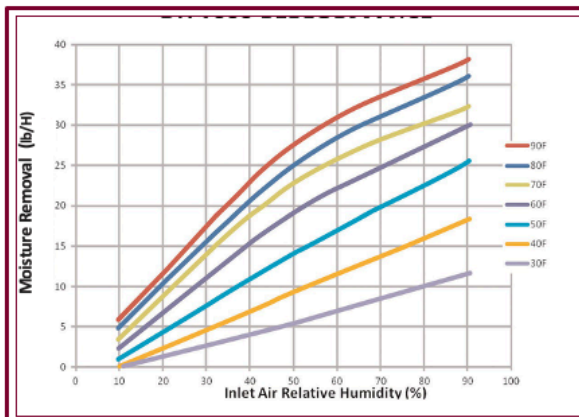

SPECIFICATIONS

Power	208-240v/ 3ph/ 60hz, FLA 47.7
	440-480v/ 3ph/ 60hz, FLA 22.0
Reactivation Heater	15 KW(max)
Process Volume	1000 CFM
Reactivation Volume	400 CFM
Process / React ESP	1"wc
Unit Weight	1200 lbs.

HOW IT WORKS

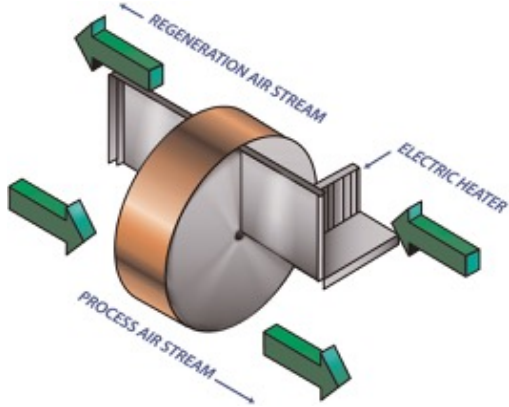

The PrecisionDRY DH 1000 draws process air through a continuously rotating desiccant wheel, where moisture is absorbed onto the desiccant surface — delivering exceptionally dry supply air. The wheel then rotates into the regeneration zone, where an electrically heated airstream drives the captured moisture out and exhausts it from the space. The result is continuous, uninterrupted ultra-low dew point performance without the limitations of refrigerant-based systems.

DIMENSIONS

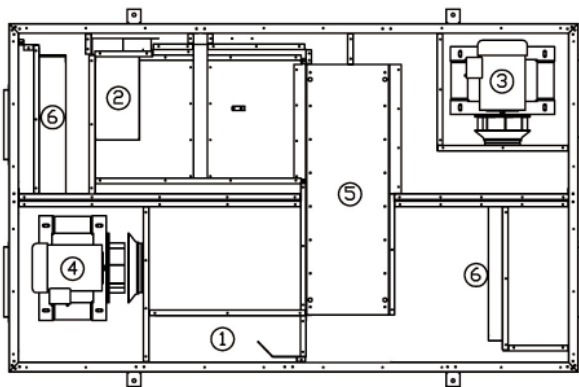

- ① ELECTRICAL
- ② ELECTRIC HEATER
- ③ EXHAUST BLOWER
- ④ SUPPLY BLOWER
- ⑤ DESICCANT WHEEL
- ⑥ FILTER

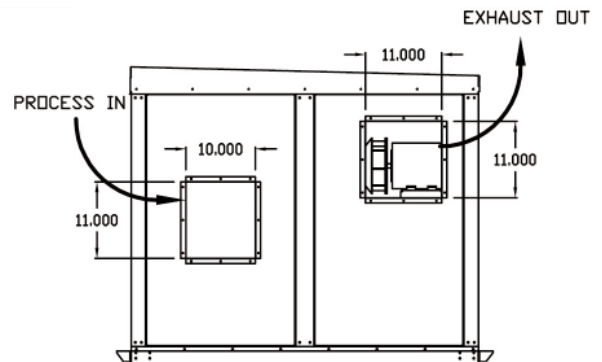
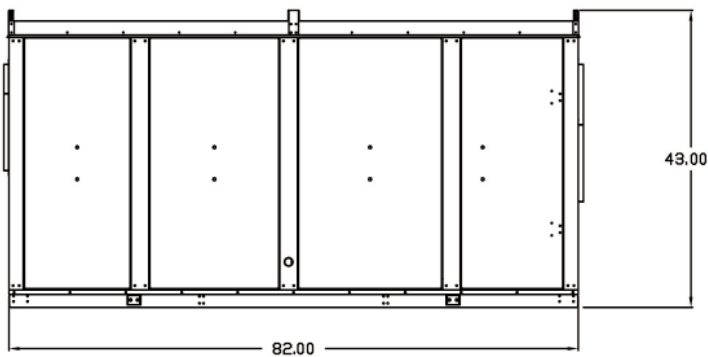
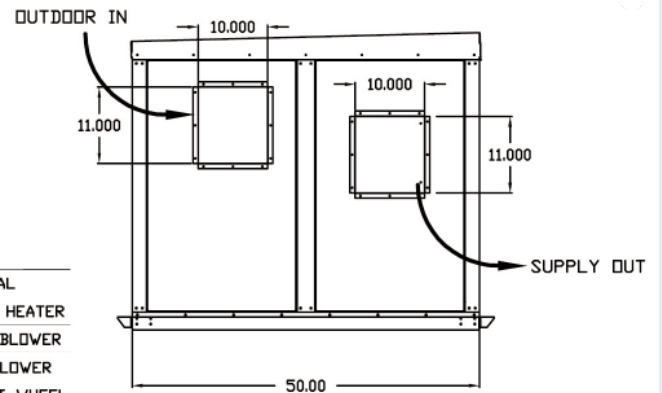

NOVELAIRE

info@novelaire.com
www.novelaire.com
unitsales@novelaire.com

10132 Mammoth Ave.,
Baton Rouge, LA 70814-4420
tel. 800.762.1320
fax. 225.930.0340



Specifications and illustrations subject to change without notice and without incurring obligation. ©NovelAire 2025. All Rights Reserved