

NOVELAIRE
Creating the Great Indoors®



DESICCANT DEHUMIDIFICATION WHEELS

Industrial Humidity Control That Protects Your Business



The NovelAire Technologies Desiccant Dehumidification Wheel (DDW) is designed to provide maximum moisture removal with a minimum pressure drop for those applications where humidity control is required. A desiccant dehumidification wheel provides the HVAC system designer with an advanced component to control humidity effectively and efficiently, particularly in the low humidity ranges.

NovelAire offers a complete line of high-performance silica gel and proprietary media desiccant wheels designed to meet a wide range of outlet humidity requirements. The overall benefits of using a DDW are:

- Improved indoor air quality.
- Precise humidity control.
- Utilizes all types of regeneration energy.
- Very low dewpoints are achievable.
- Cost effective moisture removal.

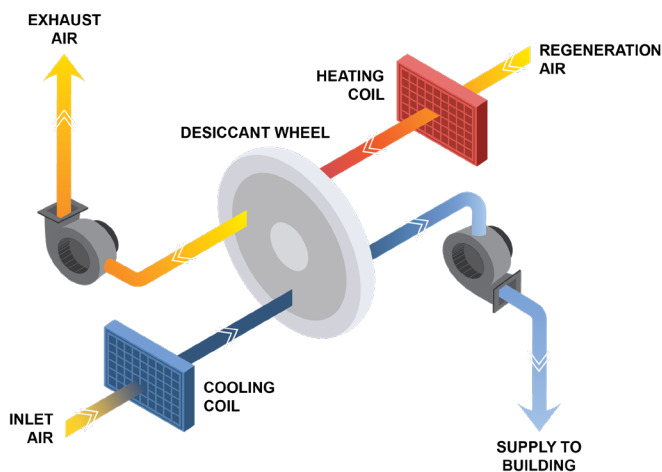

The NovelAire desiccant wheels are used extensively in the well-known industrial markets for corrosion protection and humidity control for many industrial processes. Commercial applications include refrigerated warehouses, ice rinks, schools, supermarkets, and warehouses, ice rinks, schools,

hospitals. Desiccant wheels can be used for IAQ applications to control relative humidity below 50% more efficiently for improved comfort, energy savings through higher set point temperatures, and mold and mildew prevention – all problems of increasing importance to the building owners.

NovelAire desiccant wheels are also applied in several emerging technologies including. NovelAire desiccant wheels are also applied in several emerging technologies including:

- *Desiccant Cooling* involves the use of desiccant wheels combined with indirect evaporative cooling to dehumidify and temper ventilation air more efficiently and without the use of traditional refrigerants.
- *Water-from-Air* systems incorporate desiccants to concentrate moisture that naturally occurs in the atmosphere to make condensate collection systems more efficient.

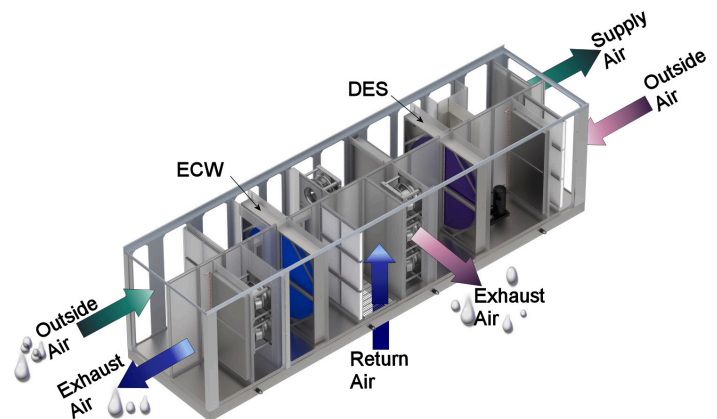

Dual wheel configuration: A desiccant wheel for dehumidification and an energy conservation wheel for heat exchange.



The choice of desiccant wheel model is tailored to each end application. The initial criteria are:

High Temperature Regeneration:

- Fiberglass Silica Gel (FSG) – Higher temperature silica gel coated fiberglass: Regen Temp. > up to 350°F

Passive / Low Temperature / Waste Heat Regeneration < 150F (typical):

- NovelAire Proprietary (DES) – Proprietary, durable media, infused with specialty adsorbent: Inlet %RH >60% to 100%
- Wound Silica Gel – Low Temp (WSG-LO) – Proprietary, durable media infused with silica gel: Inlet %RH >40%

DESICCANT TYPES

NovelAire offers high-performance silica gel and proprietary desiccants that will meet the dehumidification needs of most applications. The differences in the desiccant properties are more clearly defined by their respective static adsorption isotherm curves, a measure of the desiccant's ability to adsorb moisture under a range of fixed conditions.

The isotherm curve for the DES desiccant is non-linear and rises to a high capacity at higher relative humidity. The FSG desiccant curve exhibits higher capacity at lower relative humidity and remains linear as humidity increases. The FSG desiccant wheels are recommended when the inlet %RH is low (<60%) and/or the lowest possible outlet dewpoint is required. If the inlet %RH is high (>60%) and there is a preference for higher efficiency / low-grade heat input, then the DES

desiccant wheels are preferred. Please refer to the graph below for a visual comparison.

- DES wheels used with high inlet %RH (>60%) and when efficient removal of moisture is required.
- WSG/FSG wheels preferred with low inlet %RH (<60%) and/or when low dewpoints are required.

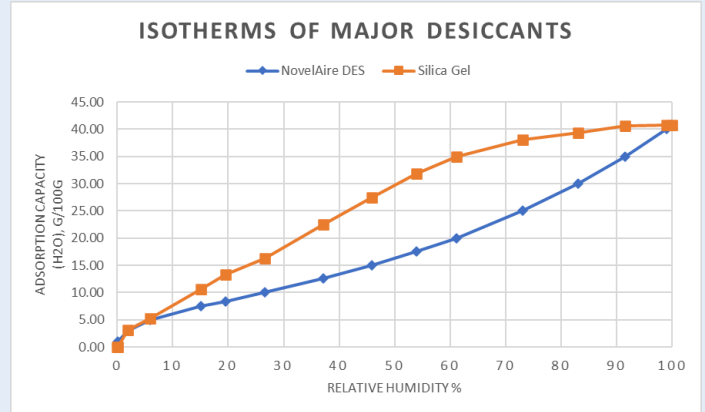

DES WHEELS

The DES desiccant wheel is designed specifically for use in applications where the inlet process air has a high %RH (such as that seen following a pre-cooling coil), and where lower temperatures are preferred for regeneration. The desiccant used in the DES wheel is uniquely formulated to maximize moisture removal in the high %RH range. Waste heat from a condensing coil or other low-grade heat can be used to regenerate the wheel.

- Specifically designed for use after a pre-cooling coil
- Can be regenerated with return air / low grade waste heat / condenser heat / solar hot water
- Available in multiple sizes: 400 cfm to 40,000 cfm



TYPICAL APPLICATION

The DES desiccant wheel is typically positioned after a cooling coil so that it processes essentially saturated air. With low-grade heat available for regeneration, the DES wheel is capable of 20 to 30 grains of dehumidification depending on regeneration temperature. When controlling humidity in a space, the DES wheel eliminates the need for overcooling and reheating.

FSG WHEELS

FSG media both utilize a high-capacity silica gel for moisture adsorption. The FSG desiccant dehumidification wheel is NovelAire Technologies' latest edition to its line of well-established desiccant rotors and employs a glass fiber substrate for higher temperature resistance. FSG desiccant wheels are used in traditional industrial and commercial dehumidification applications where low dew points are required and feature:

- High-Capacity Silica Gel Desiccant
- Reduced heat-gain effect
- High Temperature Regeneration
- Low Dewpoint / High Grain Depression capability

The FSG desiccant wheels are designed to condition air streams at face velocities of up to 1000 FPM, sustained regeneration temperatures up to 350°F and entering moisture contents from <10°F dewpoint.

FEATURES AND BENEFITS

The NovelAire FSG and DES desiccant wheels are constructed from a unique corrugated high temperature fiber-based media infused with non-migrating, high-capacity desiccants. The desiccant is uniformly and permanently dispersed throughout the matrix structure in contrast to being coated, bonded, or synthesized onto a uniform substrate, and therefore, is not susceptible to delamination or erosion of the desiccant material.

- Homogenous media. Desiccant is permanently infused into the media.
- NovelAire desiccant wheels will not dust.
- Desiccant loading of > 65%.
- Tough, non-brittle media resists damage.
- Water washable.
- High temperature resistant media for use with regeneration temperatures up to 350°F (FSG)
Used with gas, electric, steam, or hot water regeneration.

CASSETTES – FSG

- Heavy duty galvanized steel construction with removable side panels. Optional stainless-steel construction.
- Wheels are center supported, using a fixed shaft and internal maintenance-free bearings on smaller cassettes. Larger cassettes use a rotating shaft with external pillow block or flanged bearings.
- NovelAire's unique adjustable, full contact silicon bulb seal design prevents air leakage for differential pressures of up to 8" wc.
- Drive system includes a heavy-duty gear motor with chain drive and tensioner that eliminates wheel slippage.
- Cassette orientation available in a 75/25 or a 50/50 split.



CASSETTES – DES

- Heavy duty galvanized steel construction. Optional stainless-steel construction.
- Wheels are center supported, using a fixed shaft and internal maintenance-free bearings on smaller cassettes. Larger cassettes use a rotating shaft with external pillow block or flanged bearings.
- NovelAire's uniquely adjustable, full contact silicon bulb seal design prevents air leakage for differential pressures of up to 4" wc.
- Drive system includes a heavy-duty gear motor with PowerTwist® belt.
- Cassette orientation available in a 50/50 split.

Detailed wheel and cassette specifications, as well as software selection programs, are available online at : www.novelaire.com

DESIGN CONSIDERATIONS AND CONTROL STRATEGIES

Control of moisture levels in spaces or process air streams is generally accomplished by either regulating reactivation heat or bypassing a portion of the air around the dehumidification wheel. The response time, energy efficiency, and dewpoint bandwidth determine what level of control is required. The degree of control varies from the simplest form of on/off control to maintain a space condition, to the most comprehensive which would include wheel bypass dampers in addition to modulating reactivation heat to control to an adjustable supply air dewpoint.

Humidity sensors vary in type, principle of operation, accuracy, and precision, and need to be chosen to suit the control requirements. Placement of sensors in well-mixed air streams is critical to performance monitoring.

Reactivation heaters should be equipped with suitable safety devices and interlocks to prevent overheating the wheel.

The maximum regeneration operating temperature is 350°F for FSG. High temperature cutouts should be provided if this temperature could be exceeded during operation. Reactivation airflow should be maintained and proven anytime reactivation heat is energized. For DES the maximum regeneration temp is up to 150F.



WHEEL PERFORMANCE

NovelAire desiccant wheels are designed to operate with either a 75% area for process and 25% area for reactivation (75/25 split), or with 50% area for reactivation and 50% for process (50/50 split). Generally, the 75/25 split is used for industrial dehumidification, low dewpoint, and compact desiccant cooling applications. The 50/50 split is more often used for commercial cooling applications, or applications where low temperature waste heat is available for reactivation.

NovelAire desiccant wheels are designed to be reactivated with either electric resistance, indirect steam, indirect hot water, or direct/indirect fired natural or propane gas.

Additionally, solar or waste heat sources may be utilized. NovelAire desiccant wheels are designed for regeneration temperatures up to a maximum temperature of 350°F.

In addition to the regeneration temperature and cassette design, several other factors influence the performance of the desiccant wheel. Process and regeneration inlet humidity and temperature, regeneration to process flow ratio, face velocity, and wheel rotational speed all have an impact on performance. The following curves show the relationship between some of these parameters on performance for FSG desiccant wheels.

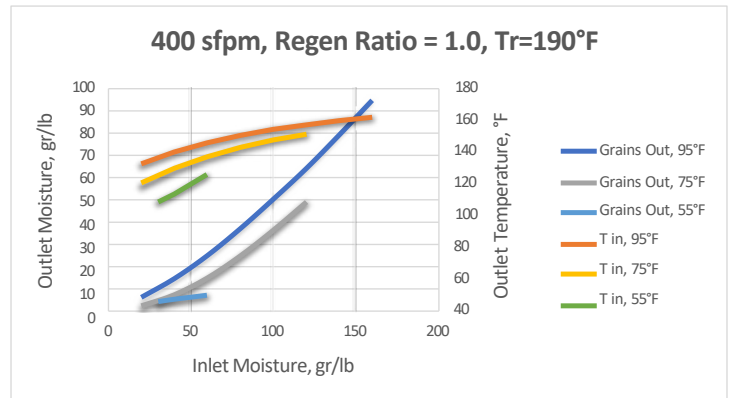
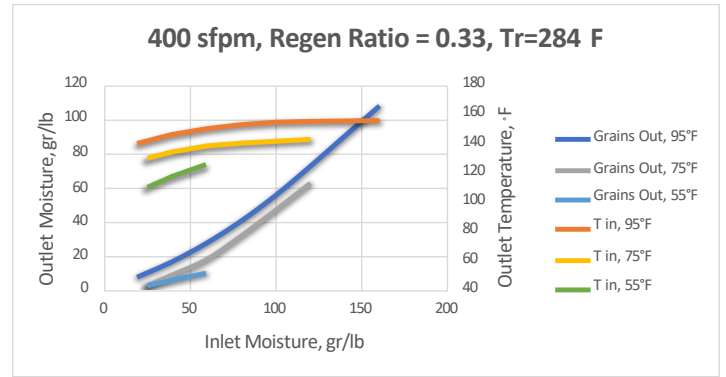

SOFTWARE SELECTION PROGRAM

For a more comprehensive analysis of performance, NovelAire offers an online model selection software program available at <https://novtools.novelaire.com>. The program models the performance of a wide array of input parameters to ensure the proper selection of desiccant wheel size and type.



NovTools —
Free, web-based
selection software
(novtools.novelaire.com)



Engineering Detail

FSG High Performance Silica Gel Desiccant

Model	Flow Rate (scfm) 75/25	Flow Rate (scfm) 50/50	Wheel Diameter (mm)	Wheel Depth (mm)	Cassette Height/Width A (inches)	Cassette Depth B (inches)	Approx. Total Wt. (pounds)	Motor Hp (Typ.)
250	200	150	250	200	21	11.5	90	1/80
370	500	350	370	200	24	12	110	1/80
440	700	500	440	200	26	12	120	1/80
550	1000	750	550	200	29	12	150	1/80
770	2000	1500	770	200	36	12	220	1/30
965	3500	2500	965	200	43	13	290	1/30
1070	4500	3000	1070	200	48	13	330	1/30
1220	6000	4000	1220	200	54	13	480	1/30
1525	8500	6000	1525	200	69	14	790	1/30
1730	11000	7500	1730	200	77	15.5	1240	1/20
1940	14000	10000	1940	200	85	15.5	1460	1/20
2190	18000	12500	2190	200	96	17	1730	1/20
2438	22500	16000	2438	200	106	17	2080	1/8
2743	28000	20000	2743	200	122	18.3	2740	1/8
3050	35000	25000	3050	200	133.8	18.3	3390	1/8

Note: NovelAire desiccant wheels are offered in a standard depth of 200 mm. Optional 50mm, 100mm, 150mm and 400mm depths are available in some sizes. Please consult the factory for depth options and dimensional tolerances.

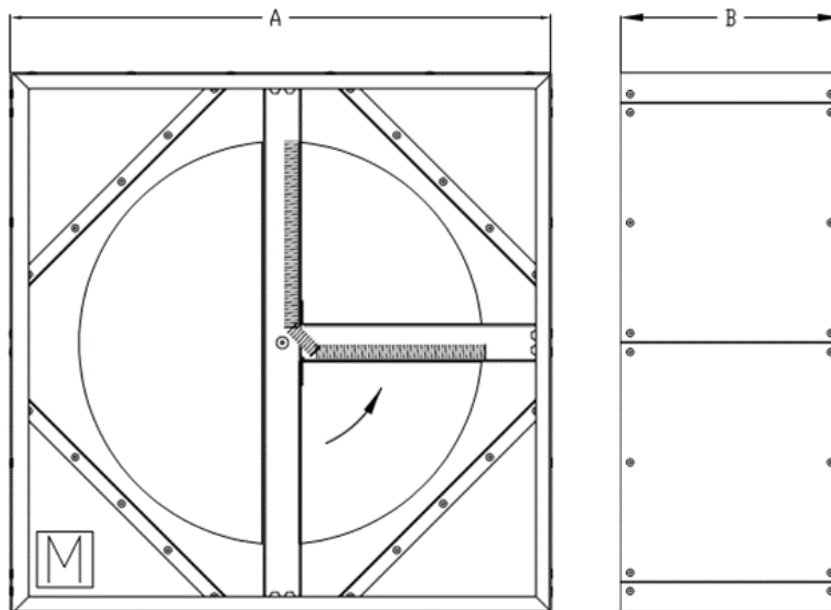

Engineering Detail

DES NovelAire's Proprietary Desiccant

Model	Nominal Air-flow (scfm)	Wheel Diameter (inches)	Wheel Depth (inches)	Cassette Height & Width A (inches)	Cassette Depth B (inches)	Approx. Total Wt. (pounds)	Motor HP (Typ.)
DES204	750	20	4	23	7	40	1/80
DES244	1000	24	4	27	7	70	1/80
DES284	1400	28	4	34	7	105	1/80
DES324	1800	32	4	39	7	160	1/50
DES364	2400	36	4	42	7	190	1/50
DES424	3200	42	4	48	7	200	1/50
DES484	4200	48	4	54	8	270	1/50
DES486	4200	48	6	54	10	310	1/50
DES544	5400	54	6	60	8	320	1/50
DES546	5400	54	4	60	10	350	1/50
DES604	6800	60	6	66	8	440	1/50
DES606	6800	60	6	66	10	540	1/50
DES664	8200	66	4	72	9	540	1/50
DES666	8200	66	6	72	11	630	1/50
DES724	10000	72	6	78	9	670	1/50
DES726	10000	72	4	78	11	700	1/50
DES784	12000	78	6	84	9.5	720	1/50
DES786	12000	78	4	84	12	880	1/50
DES844	14000	84	6	90	9.5	810	1/50
DES846	14000	84	6	90	12	1050	1/50
DES906	16000	90	6	96	12	1130	1/50
DES966	18000	96	6	102	12	1400	1/50
DES1026	20000	102	6	108	12	1630	1/50
DES1086	22500	108	6	116	15	2200	1/20
DES1206	27500	120	6	129	15	2750	1/20
DES1326	32500	132	6	140	15	3070	1/20

NOVELAIRE

CREATING THE GREAT INDOORS®

10132 Mammoth Avenue, Baton Rouge, LA 70814-4420

Phone: (800) 762-1320 / (225) 924-0427 | Fax: (225) 930-0340
Website: www.novelaire.com | Email: info@novelaire.com

