

PHOENIX 4800E

Industrial Desiccant Dehumidifier Advanced Humidity Control

The **Phoenix 4800E** Industrial Desiccant Dehumidifier is built with the restorer in mind. Its ease of use and its reliability on the job site are two of its most exceptional features. The robust construction is designed to withstand the rigorous conditions of extreme operating environments. Typical applications include:

- Water damage restoration
- On & off shore petrochemical facilities
- Manufacturing plants
- General rental industry
- Shipyards



FEATURES

- Fits in the bed of a pickup truck
- All aluminum construction for maximum strength, light weight, and corrosion resistance
- Removes 3000+ pints per day with 4800 cfm process air flow
- Wide operating range of -10°F to 140°F
- Maintenance access from both sides
- On board controls ensures constant optimum operation
- Dew points as low as -40°F
- ETL certified

HOW IT WORKS

The heart of the **Phoenix 4800E** unit is a rotating desiccant wheel. Moisture laden air is drawn through the desiccant wheel where it adsorbs moisture onto the desiccant surface. The bone dry process air leaving the wheel is ducted back to the space. As the wheel rotates into the regeneration section, heated regeneration air releases the adsorbed moisture from the wheel which is then ducted outside via the exhaust.

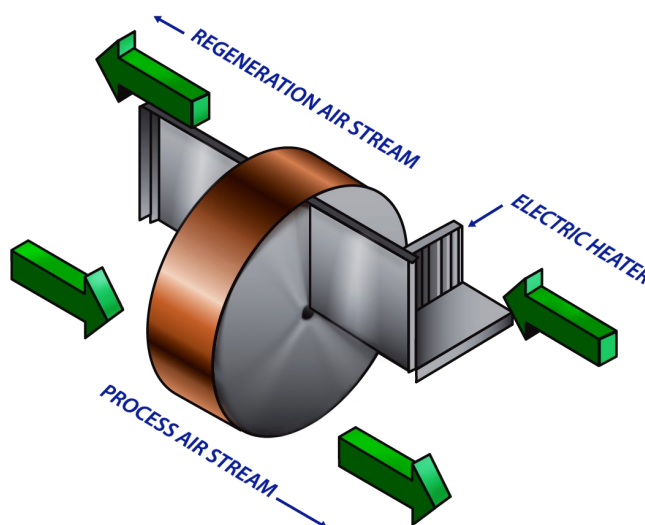

PHOENIX 4800E—Industrial Desiccant Dehumidifier

SPECIFICATIONS

Power:

480v/3ph, FLA 106

Process volume:

4800 cfm

Reactivation volume:

2000 cfm

Water removal:

3032 PPD (3162 lb/hr) @ 80°F / 60% RH

Filters:

20" x 20" x 2" metal mesh - qty 2 (process)

20" x 20" x 2" metal mesh - qty 1 (reactivation)

Operating Range:

-10°F to 140°F

Unit Weight:

1550 lbs (desiccant module only)

1675 lbs (desiccant with frame)

Warranty:

1 year parts and labor

2 years on the desiccant parts only

Options:

4800E (Std) with frame

4800E-1 without frame

4800E-2 with frame and docking station*

4800E-3 without frame and docking station*

*For generator connection

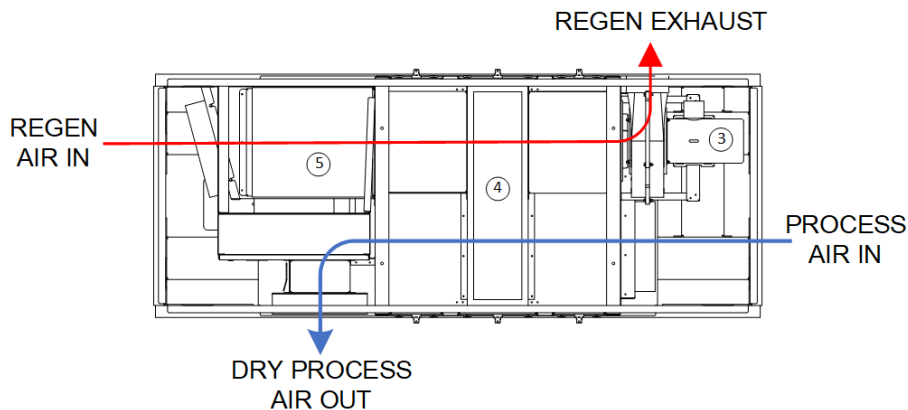

ITEM DESCRIPTION

- | ITEM | DESCRIPTION |
|------|------------------|
| 1 | ELECTRICAL |
| 2 | SUPPLY FAN |
| 3 | REGEN FAN |
| 4 | DESICCANT WHEEL |
| 5 | ELECTRIC HEATERS |
| 6 | FILTER |

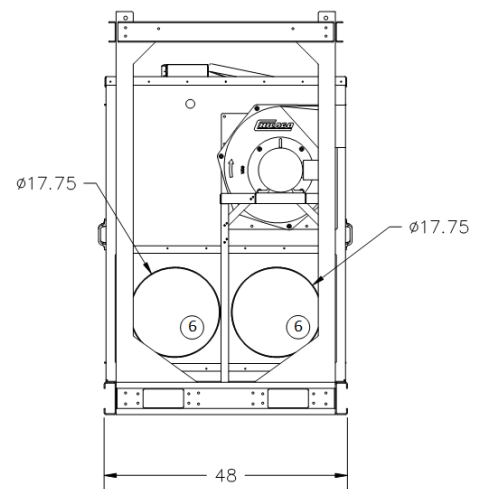
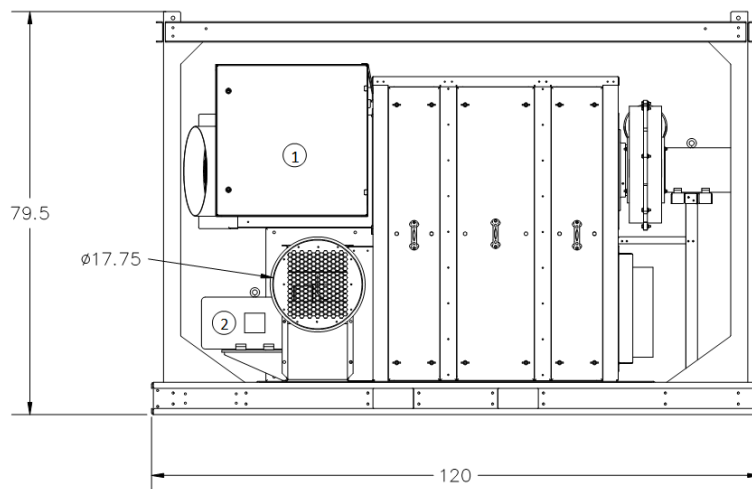

NOVELAIRE TECHNOLOGIES®

Creating the Great Indoors®

10132 Mammoth Ave., Baton Rouge, LA 70814-4420

tel. 225.924.0427 / 800.762.1320 | fax. 225.930.0340

www.novelaire.com | sales@novelaire.com



The information contained in this document is believed to be accurate by NovelAire Technologies but is not warranted.

