

DH-250

advanced humidity control commercial desiccant dehumidifier



The DH-250 desiccant dehumidifier is designed to be used in a wide range of applications where low dewpoints are required. Typical applications include: dehumidifying storage rooms, vaults, small manufacturing centers and refrigerated storage rooms. The DH-250 is capable of controlling the humidity in a space well below that which can be obtained with conventional refrigeration type dehumidifiers. The DH-250 relies on NovelAire's "state-of-the-art" desiccant wheel technology to deliver ultra low dewpoints.

HOW IT WORKS

The DH-250 unit effectively removes moisture at any temperature without the freeze up problems inherent with refrigerant dehumidifiers. The desiccant based process enables the unit to achieve and maintain lower relative humidities and lower dewpoints than conventional DX type dehumidifiers.

The heart of the unit is a rotating desiccant wheel. Return air from the conditioned space is drawn through the rotating desiccant wheel. The desiccant adsorbs moisture from the air stream and the bone dry supply air is returned to the conditioned space. The moisture containing portion of the wheel rotates into the regeneration section where the desiccant releases the adsorbed moisture into the heated regeneration air stream which is then exhausted to the outside.

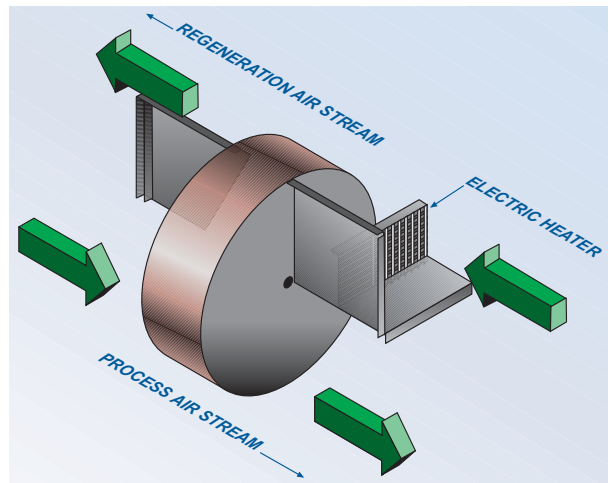

BENEFITS

- Achieve ultra low dewpoints
- Controls from remote humidistat
- Compact size, lightweight and portable
- Solid construction

DH-250

SPECIFICATIONS

Power:	220 V, 1PH, 60 HZ
	FLA 22.5
Weight:	95 lbs
Process Volume:	180 CFM
Regeneration Volume:	75 CFM
External Static:	0.2 IN WC

PERFORMANCE

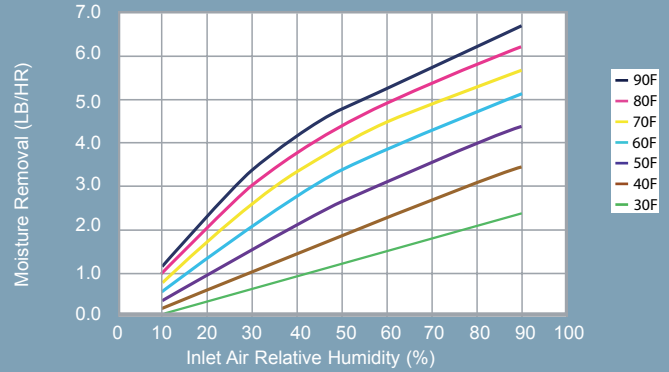

DIMENSIONS

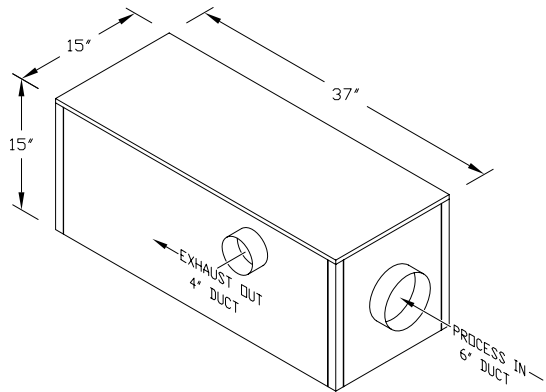
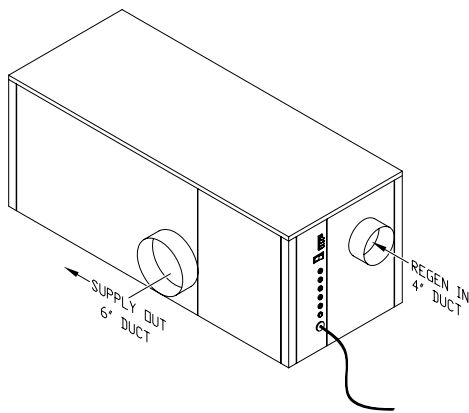

INSTALLATION

NOTE:
Both regen and process inlet ducts can be either duct connections as shown or as a square grill inlet as shown in the photo on the front page. Both are provided.

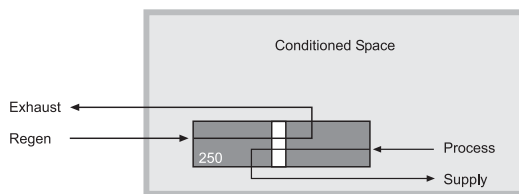

OR

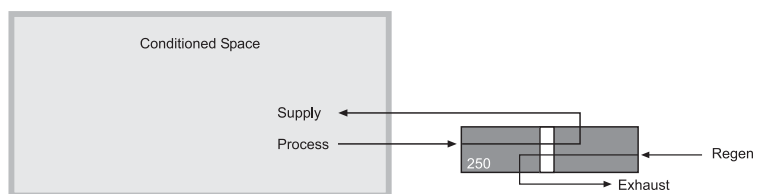

SPECIFICATIONS SUBJECT TO CHANGE WITHOUT NOTICE. CONSULT FACTORY FOR SPECIAL APPLICATIONS.

NOVELAIRE TECHNOLOGIES
Creating the Great Indoors®

10132 Mammoth Ave, Baton Rouge, LA 70814-4420
tel. 800-762-1320 / 225-924-0427 fax. 225-930-0340
www.novelaire.com



The information contained in this brochure is believed to be accurate by NovelAire Comfort Products but is not warranted.