

# 300 DES/DX

## advanced humidity control desiccant dehumidifier

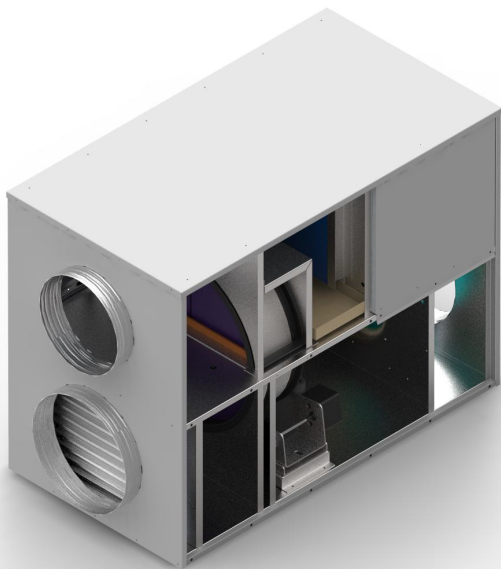

The 300 DES/DX desiccant-based dehumidifier is designed specifically for light commercial applications. The unit combines the benefits of both desiccant dehumidification and DX cooling to achieve the most energy efficient dehumidification. Waste heat is captured from the condensing coil and used to regenerate the desiccant rotor in order to provide further dehumidification.

- Dehumidify without raising the supply air temperature

### HOW IT WORKS

The core of the **DES/DX** dehumidifier is a DX refrigeration loop coupled with a desiccant dehumidification wheel. In dehumidification mode, return air passes first through the evaporator coil where it is cooled and typically experiences some dehumidification and then through the desiccant wheel where the air is dried to a low dewpoint. In the isolated regeneration section of the unit, outdoor air is used to capture rejected condenser heat and regenerate (dry) the desiccant wheel. The wet air exiting the regeneration half of the desiccant wheel is exhausted.

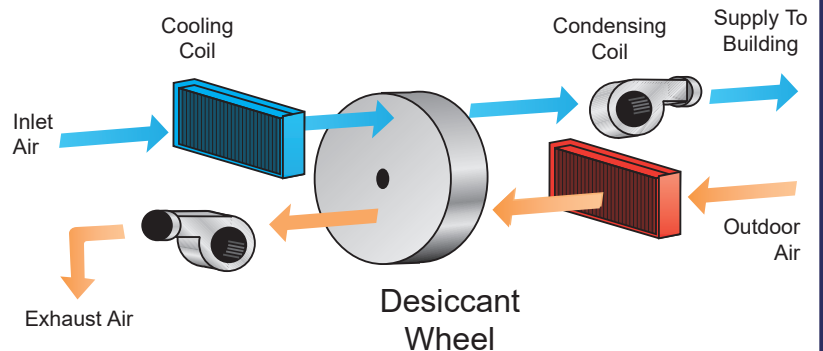

### BENEFITS

- The most energy efficient humidity control
- Saves energy by maintaining comfort at higher set point temperatures
- Prevents mold, mildew, and dust mite growth by maintaining 50% RH
- Independent humidity control without raising supply air temperature
- Improves comfort
- Works independent of the HVAC system
- ETL listed

# 300 DES/DX

## SPECIFICATIONS

Dimensions:	(H) 30in x (L) 40in x (W) 22in
Weight:	220 lbs
Process Flow:	300 cfm
Power:	208/203v/60hz/1ph FLA 9.3
ESP:	.5 in wc
Control:	24 vac
Refrigerant:	R-410A
Cooling Capacity:	9,000 Btu/hr
Dehumidification Capacity:	211 pints/day (78F, 60% RH)

Indoor installation only

\*Based on 85/76 DB/WB outdoor air conditions

## PERFORMANCE

Process In		Supply Out*		lb/HR H <sub>2</sub> O Removed
T DB F	%RH	T DB F	%RH	
80	60	81	28	9.4
80	55	80	27	8.4
76	60	76	29	8.2
76	55	76	27	7.3
72	60	73	28	7.2
72	55	73	26	6.3
70	60	71	28	6.6
70	55	70	28	5.8
65	60	65	30	5.4
65	55	64	30	4.7

## DIMENSIONS

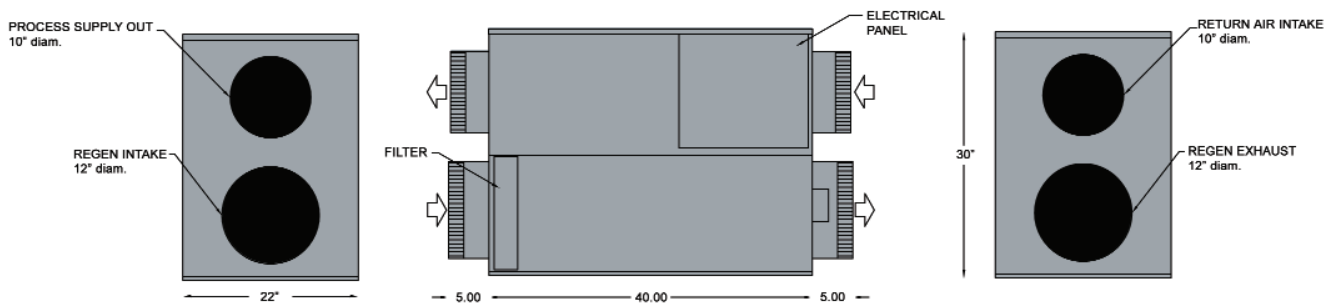

## INSTALLATION

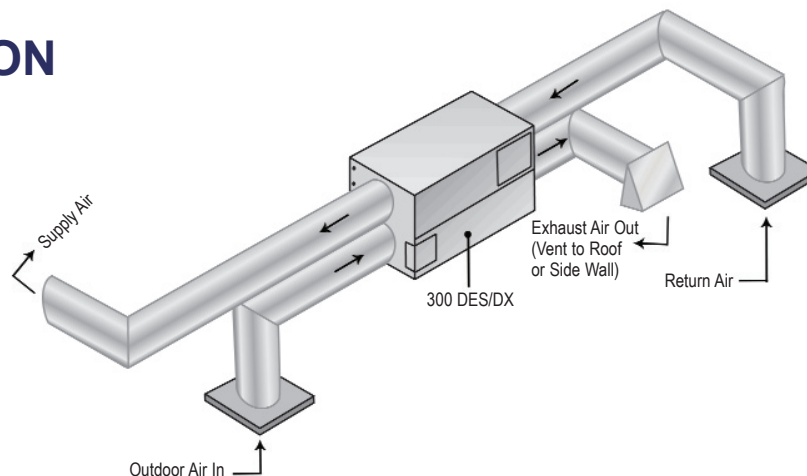

The 300 DES/DX is typically installed as shown with its own return air and supply ducts. The supply air ducts is branched to two or three supply air ducts servicing main rooms of the building. The 300 DES/DX is controlled by a separate humidistat and will cycle on and off to control humidity independently of the main A/C system.

**NOVELAIRE TECHNOLOGIES**  
Creating the Great Indoors

10132 Mammoth Drive, Baton Rouge, LA 70814-4420  
tel. 800-762-1320/225-924-0427 fax.225-930-0340  
www.novelaire.com