

NOVELAIRE *Comfort* PRODUCTS

# COMFORTPLUS™ 300

advanced humidity control  
residential desiccant dehumidifier



The ComfortPlus™ 300 desiccant-based dehumidifier is designed specifically for residential and light commercial applications. The unit combines the benefits of both desiccant dehumidification and DX cooling to achieve the most energy efficient dehumidification. Waste heat is captured from the condensing coil and used to regenerate the desiccant rotor in order to provide further dehumidification.

## HOW IT WORKS

The revolutionary new technology of NovelAire's Comfort Wheel™ is specifically designed to maximize moisture removal and comfort in your home. Moisture from the return air is first dried by the evaporator coil and then is further dehumidified as it passes through the Comfort Wheel. The moisture-laden wheel then rotates into the outdoor air stream where the waste heat from the condenser coil heats the outdoor air so that it dries the wheel and discharges the unwanted excess moisture outdoors.

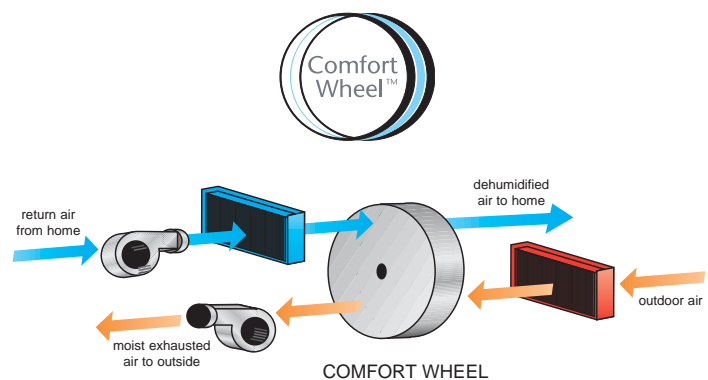

## BENEFITS

- The most energy efficient humidity control
- Saves energy by maintaining comfort at higher set point temperatures
- Prevents mold, mildew, and dust mite growth by maintaining 50% RH
- Independent humidity control without raising supply air temperature
- Improves comfort
- Works in conjunction with or independent of the HVAC system

# COMFORTPLUS<sup>TM</sup>300

## SPECIFICATIONS

Dimensions: (H) 30in x (L) 40in x (W) 22in  
 Weight: 220 lbs  
 Process Flow: 300 cfm  
 Power: 208/230v/60hz/1ph  
 1.5KW, FLA 6.7  
 (variable with load)  
 Control: 24 vac  
 Refrigerant: R-410A  
 Cooling Capacity: 9,000 Btu/hr  
 Dehumidification Capacity: 200 pints/day (78F, 60% RH)  
 Sized For: Up to 3000 sq. ft. typical

Available in indoor and outdoor models

\*Based on 85/76 DB/WB outdoor air conditions

## PERFORMANCE

Process In		Supply Out*		lb/HR H <sub>2</sub> O Removed
T DB F	%RH	T DB F	%RH	
80	58	79	30	8.5
80	51	77	30	7.3
78	60	79	29	8.4
78	53	76	29	7.2
76	63	78	29	8.5
76	56	76	29	7.2
74	66	77	29	8.5
74	58	74	28	7.2
72	69	75	28	8.4
72	61	73	28	7.2

## DIMENSIONS

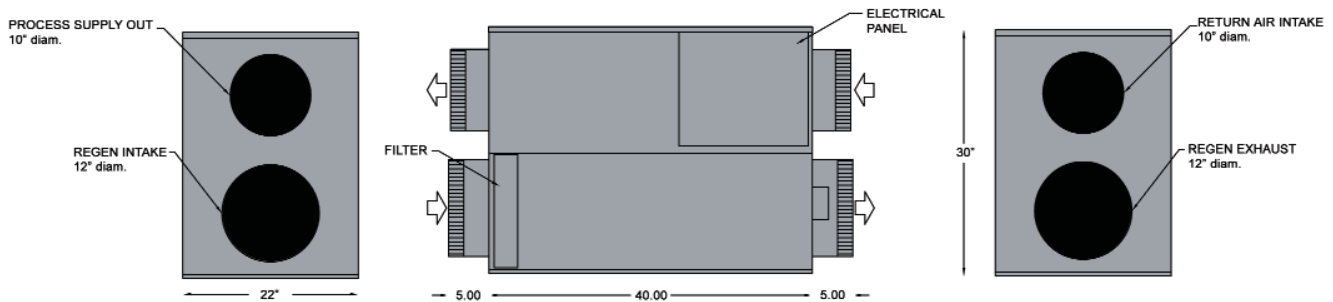

## INSTALLATION

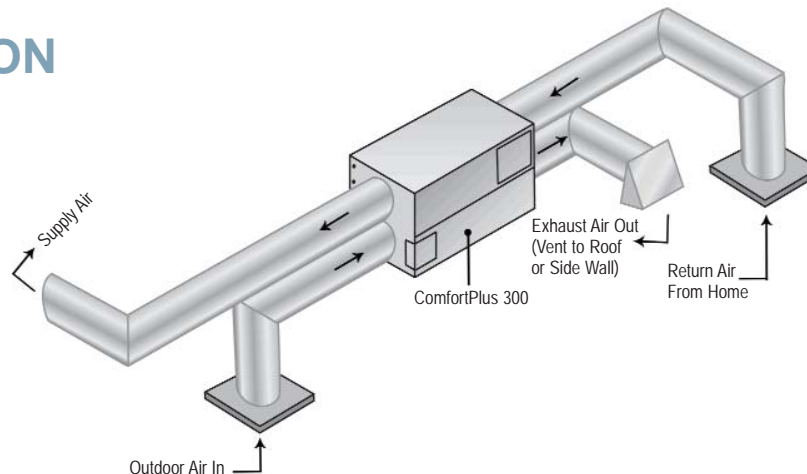

The ComfortPlus 300 is typically installed as shown with its own return air and supply ducts. The supply air duct is branched to two or three supply air ducts servicing main rooms of the home. The ComfortPlus 300 is controlled by a separate humidistat and will cycle on and off to control humidity independently of the main A/C system.

The ComfortPlus 300 can also be tied into the main A/C air handling system downstream of the evaporator coil. In this configuration, the unit needs its own return air system and the supply air tie-in needs a gravity damper to prevent back flow.

**NOVELAIRE** *Comfort* PRODUCTS  
 creating the great indoors.

10132 Mammoth Drive, Baton Rouge, LA 70814-4420  
 tel. 800-762-1320/225-924-0427 fax.225-930-0340  
 www.novelaire.com

The information contained in this brochure is believed to be accurate by NovelAire Comfort Products, but is not warranted.